

- 1.MATERIAL:
 MOLDING: LCP UL94 V-0
 CONTACT:COPPER ALLOY.
 SHELL: SUS304-H,T=0.30±0.03mm
 50u" NICKEL PLATING OVER ALL.
 SHILD:SUS304-H,T=0.12±0.03mm
- 2.MECHANICAL:
 INSERTION: 5~20N.
 EXTRACTION: 8~20N.
 DURABILITY: 5000 CYCLES
- 3.ELECTRICAL:
 CURRENT: 3A MIN FOR VBUS;
 VOLTAGE: 5VAC MAX
 WITHSTANDING VOLTAGE: 100V AC.
 CONTACT RESISTANCE: 40mΩ MAX.
 INSULATION RESISTANCE: 100MΩ MIN.
- 4.ENVIRONMENTAL
 TEMPERATURE RANGE -55°C ~ +85°C

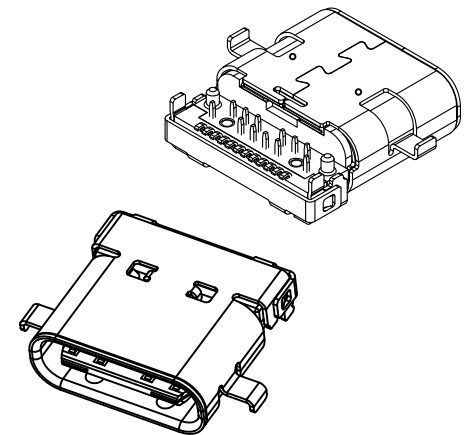
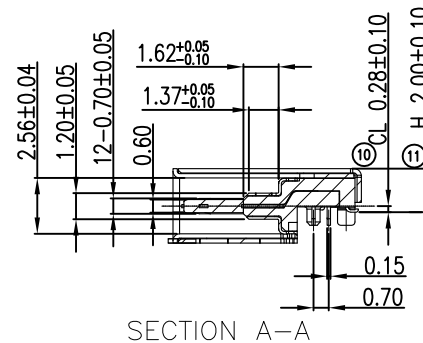
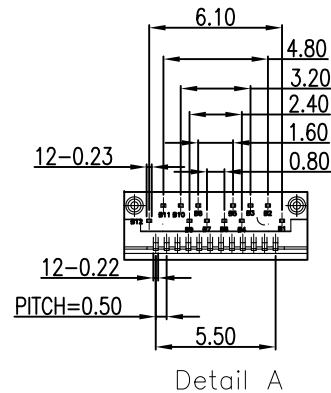
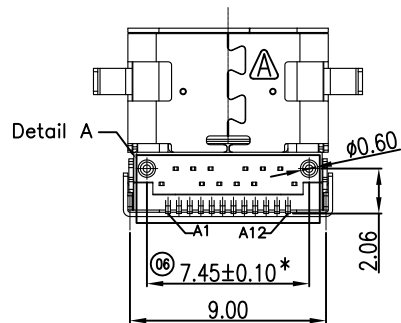
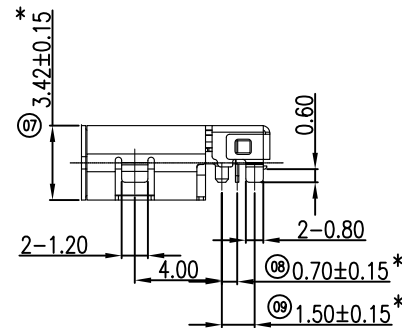
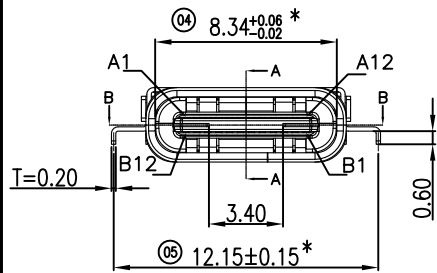

HE 东莞市旭明电子有限公司

REV	DATE	DESCRIPTION	NAME	APPRO.	0	±0.25	DESIGN		
A	19'/05/20	更新图画、增加点焊	HQ	LZX	0.0	±0.20	CHECK		
0	18'/06/30	NEW	Wyl	Dave	0.00	±0.15	APPRO.		
					GENERAL TOLERANCE UNLESS OTHERWISE NOTED				

TITLE:	USB 3.1 C/F CL0.28 H2.00mm DIP TYPE 针长0.6			
PART NO.	UCA0009-000	CUSTOMER NO(REV)	1G	UNIT:mm
FILE NAME	180630-01	SHEET: 1 of 2	SCALE: 1:1	A4